

Signal Conditioners for Position Measurement

MUP 100 Series



Special features

- interface module for position sensors
- available with electrical isolation (DC/DC transformer) as an option
- standardized output signals
0...10 V
 \pm ...10 V
0...20 mA
4...20 mA
 \pm ...20 mA
- outstanding linearity
- extremely low temperature drift
20 ppm/K (typical value)
- designed for standard DIN EN 50022 mounting rail fixture

The signal conditioner supplies potentiometric sensors with a highly stable constant voltage. The wiper signal is picked off without load via a high-resistance input stage and transformed into a proportional standardized output signal.

The excellent linearity and low temperature drift ensure full utilization of the outstanding benefits of conductive plastic potentiometers, guaranteeing the reliable, interference-free

transmission of signals for installations with close sensor proximity to noise sources even over long distances.

The zero point and range can be adjusted independently of each other within wide limits using spindle trimmers. This capability permits standardized output signals to be adjusted even if the maximum path of the sensors is not completely utilized. The electronic circuitry is accommodated in a polyamide housing designed to clip on a standard DIN EN 50022 mounting rail. A wide range of operating voltages can be supplied by an un stabilized direct voltage source.

High-grade DC/DC transformers are used in the models with electrically isolated supply voltage and signal conditioning. Both for the unipolar and bipolar standard output signals, only one configuration is required.

The MUP 150 provides an additional output signal of \pm 15 V to support AW series potentiometers.

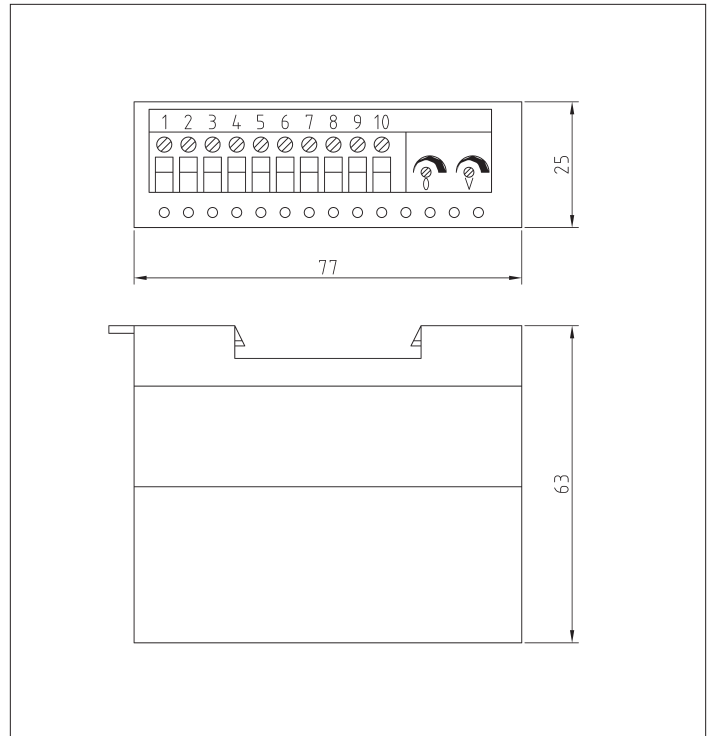

Mechanical Data

Dimensions	see drawing	
Protection class	IP 50 / IP 00 (clamps)	
Screw-type terminals	1.5 (AWG 14)	mm ²
Mounting rail fixture	35 (DIN EN 50022)	
Weight	appr. 110	g

Electrical Data

Operating voltage	18...30	VDC
Input resistance	> 10	M Ω
Reverse voltage protection	integrated	
Current consumption	70	mA
Internal reference voltage for the position transducer, highly stable and short circuit-proof	10	VDC
Permissible connection resistance of the position transducer	\geq 700	Ω
Adjustment range		
Zero point	-30...+20	%
Gain	0.65...2	
Linearity	0.01 (typical)	%
Temperature coefficient*	20 (typical)	ppm/K
Temperature range	-25...+70	$^{\circ}$ C

*The TC applies for current and voltage outputs. If, at current outputs, the voltage is picked off at the load resistor, the TC of the resistor must also be taken into consideration.

Connection diagram

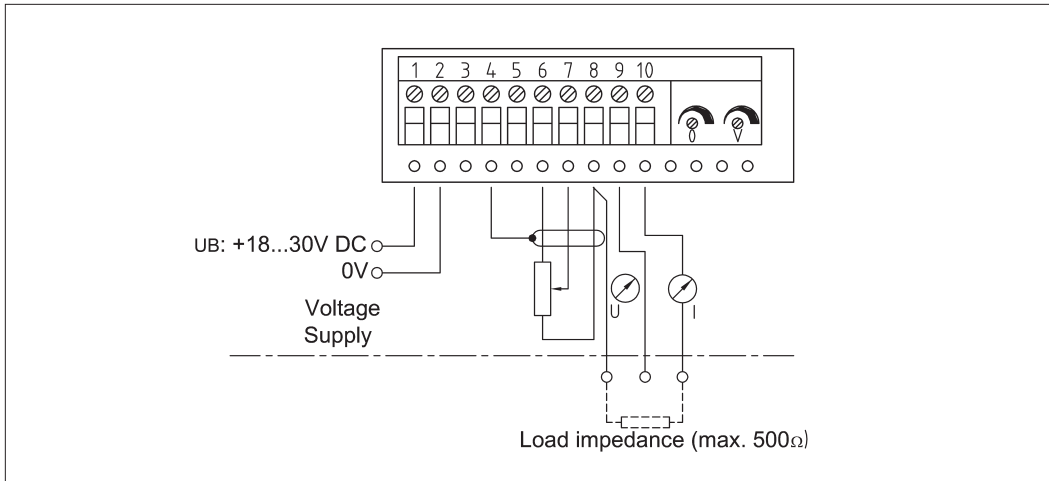

Order designation

Series	Type	Output	Art. no.
M U P	100	0 = 0...20 mA (burden impedance max. 500 Ω)	054001
	Series 100 without galvanic isolation	1 = 0...10 V (I max. 20 mA short circuit-proof)	054002
		4 = 4...20 mA (burden impedance max. 500 Ω)	054003
	150*	Series 150 with galvanic isolation	5 = 0...10 V (I max. 20 mA short circuit-proof)
0(4)...20 mA (burden impedance max. 500 Ω)			054052
6 = ±10 V (I max. 20 mA short circuit-proof)			
		±20 mA (burden impedance max. 500 Ω)	

* Typ. 150 with additional voltage source of ±15 V (at clamp 3, 4 and 5) for further use.

Other configurations available on request:

- without adjusting trimmer
- with other output signals
- with extended adjustment ranges